

Multi-layered Fabric Electrode for Movement Artifact Reduction in Capacitive ECG Measurement

Yasuhiro Fukuyama, Ryutaro Suzuki, Shunsuke Takayama, and Akinori Ueno, *Member, IEEE*

Abstract—An electrode configuration composed of multi-layered fabric electrodes were examined and compared with that composed of non-layered fabric electrodes in terms of movement artifact reduction when using the electrodes in capacitive electrocardiogram measurement from human buttocks in a vibrating environment. Experiments performed with six participants revealed that the multi-layered configuration composed of sensing electrode, driven shield and ground layers reduced amplitude of movement artifact significantly than the non-layered configuration.

I. INTRODUCTION

The aging of the developed societies has increased the needs for efficient systems that monitor health status of the elderly in many situations. And monitoring of heart activity such as electrocardiogram (ECG) is beneficial for the health management and early detection of heart disease. Capacitive ECG measurement has strong advantages in that commercial thin clothing can be mediated between measuring electrodes and the human body, and also in that the electrodes can easily be embedded in furniture, such as a bed [1] or chair [2], and in automobile equipment, such as seat [3] or steering wheel [4], with no loss of operability and safety.

Our research group proposed a fundamental approach for capacitive sensing of ECG and confirmed a basic feasibility of the approach in 2004 [5]. Subsequently, we applied this approach for ECG measurement from the back of lying participant in 2007 [1]. In 2008, we reported preliminary results of ECG detection from the buttocks of sitting driver while automobile driving [3]. However, mean detection rate of R-wave of ECG for 10-minute driving on a general road was only 70.6 %. Presumably, this was caused by movement artifact in capacitive ECG measurement due to mechanical vibration caused by bumps of the road and driving action by their legs. Therefore, the vibration sensitivity of the capacitive ECG recording must be reduced to obtain a higher detection rate particularly for automotive applications.

Other research groups have explored other electrode sites such as backrest [6] or steering wheel combined with seating surface [4], [7], [8]. Besides, Wartzek et al. has reported a software approach based on principal component analysis [9]. Nevertheless, the detection ratio has not reached to a practical level yet.

Y. Fukuyama is with Nissan Research Center, Nissan Motor Co., Ltd., Kanagawa, 243-0123 Japan (corresponding author to provide phone: +81-50-2029-1364; e-mail: ya-fukuyama@mail.nissan.co.jp).

R. Suzuki and S. Takayama are Undergraduate Students in Department of Electrical and Electronic Engineering, Tokyo Denki University, Japan.

A. Ueno is with the Department of Electrical and Electronic Engineering, Tokyo Denki University, Tokyo, 120-8551 Japan (phone: +81-3-5284-5404; fax: +81-3-5284-5404; e-mail: ueno@mail.dendai.ac.jp).

In this study, on the hypothesis that movement artifact in capacitive ECG measurement is presumably caused by interference of triboelectricity due to mechanical vibration, we prototyped multi-layered fabric electrodes and examined whether it has an effect in reducing movement artifact in the measurement.

II. MEASURING SYSTEM AND METHODS

A. Configuration of Fabric Electrode Unit

Two configurations of type A and B in Fig. 1 were prepared and used in subsequent evaluations. Carbon-coated conductive fabric of 100 μm thick (Kitagawa Industries Co. Ltd., CSTK) was used for the material of sensing electrode, driven shield, ground (GND) electrode and GND layer in all configurations. Polyester woven fabric of 80 μm thick was used for insulators. Shape of the sensing electrode in the surface was rectangle of 7200 mm^2 . In the configuration of type B, we expected the ground layer surrounding the sensing electrode and the driven shield protects the electrode from triboelectric interference. The driven shield was expected to reduce leakage from the sensing electrode to ground layer and to keep the sensing electrode being in high impedance in the same manner of guard ring.

B. Electronic Circuit for ECG Measurement

Fig.2 shows block diagram of the electronic circuit for ECG measurement. In each configuration in Fig. 1, two signals detected from the sensing electrodes were subtracted and amplified by the instrumentation amplifier. The output signal was filtered, further amplified and converted to digital signal. Operational amplifier IC (Texas Instruments Inc., OPA134) having high input-impedance (10 T Ω , 2 pF) was used for the buffer circuits to suppress voltage loss at each electrode coupling to the human body via clothing. A notch filter (NF Corp., SR-2BE1) was introduced to reduce power-line interference because fundamental experiments were to be conducted in an indoor laboratory. As for the use in automobile cabins, the filter can be removed. Pass band of the subsequent filter was set to the range from 10 to 40 Hz for detecting QRS complex of ECG. Total gain of the measuring circuit was set to 60 dB. A/D conversion was conducted using commercial A/D converter (BIOPAC Systems Inc., MP-150) at 1,000 Hz sampling with 16 bit resolution of ± 10 V.

C. Measurement of Frequency-Gain Characteristics

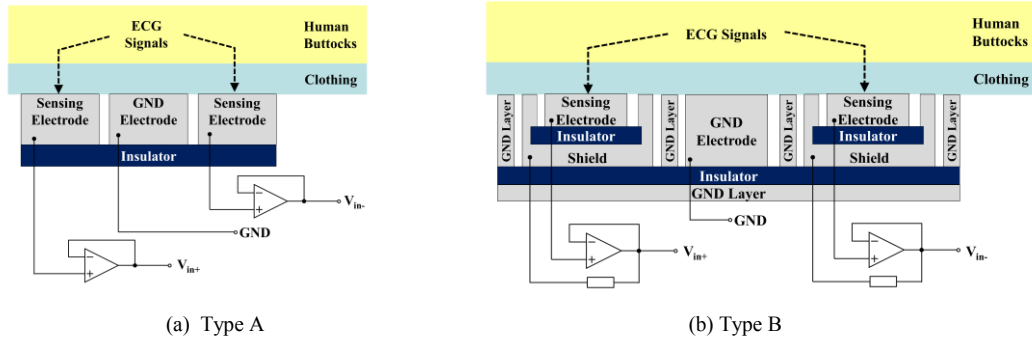

Figure 1. Side-viewing cross-sectional configurations of tested fabric electrode unit for capacitive ECG measurement.

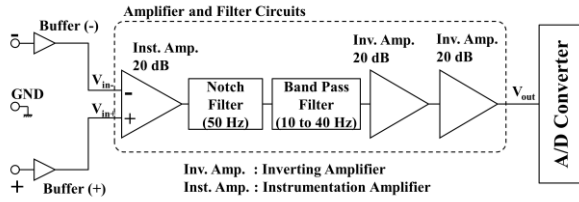

Figure 2. Block diagram of the electronic circuit for ECG measurement.

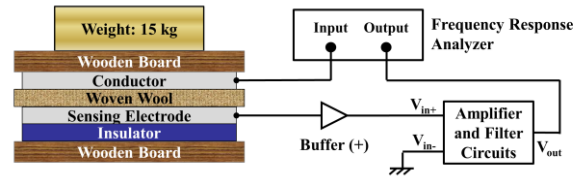

Figure 3. Experimental setup for measuring frequency-gain characteristics.

Experimental setup for measuring frequency-gain characteristics is shown in Fig. 3. In order to compare gain attenuation between two configurations, a woven wool cloth 460 μm thick was inserted between the electrode unit and a fabric conductor for leading source signal. A pressure mimicking subject's weight was applied homogeneously onto the wool cloth using a 15-kg weight and a wooden board. The fabric conductor and the output terminal of the measuring circuit were connected to a frequency response analyzer (NF Corp., FRA5022). A frequency-gain characteristic of the electronic circuit with the each electrode unit in Fig. 1 was measured from 1 to 400 Hz by the analyzer.

D. Measurement of ECG and Analysis of Signal-to-Noise Ratio using ECG Generator

Each electrode unit in Fig.1 was connected to the electronic circuit in Fig.2. The woven wool, wooden boards and weight were used as shown in Fig3 and in the same manner as in subsection II-D. Simulated ECG signal from an ECG generator (Nihon Kohden Corp., AX-301D) was substituted for the source signal of the frequency response analyzer in Fig.3. Output signal was digitally recorded in the same way as in subsection II-B.

Digitally recorded ECG signal was analyzed off-line to calculate signal-to-noise ratio (SNR) using equation (1).

$$SNR_{AVE} = 10 \log \left(\frac{1}{K} \sum_{i=1}^K \frac{S_i^2}{N_i^2} \right) \quad (\text{dB}) \quad (1)$$

Where K is the number of data and ten was used in this study. Signal (S_i) was obtained by subtracting N_i from S_i' . S_i' was defined as a sum of spectrum powers from 10 to 40 Hz of i -th ECG segment. The ECG segment was extracted from the recorded ECG signal with duration of 0.2s from -0.1s to +0.1s

with reference to the peak of i -th QRS complex. Noise (N_i) was defined as a sum of spectral powers of non-ECG segment from 10 to 40 Hz. The non-ECG segment was extracted also from the recorded ECG signal with duration of 0.2 from -0.1s to +0.1s with reference to the midpoint between the peaks of i -th and $(i+1)$ -th QRS complex. The standard deviation and significance were also calculated from ten ratios of S_i^2 and N_i^2 .

E. Measurement of Movement Artifact on ECG and Analysis of the Amplitude

Fig. 4 shows experimental setup for measuring ECG and movement artifact. Six healthy males (hereafter participant P1 to P6, ranging in age from 22 to 24 years) participated in this experiment. The study was approved by the Institutional Review Board of Tokyo Denki University. Prior to the experiment, the experimental protocols were explained to the participants, who then provided written informed consent.

Each electrode unit in Fig. 1 was placed on the cushion made from urethane foam covered with leather. The participants wore clothes made of cotton 440 μm thick and sat on the cushion with the fabric electrode. ECG of the participants was measured from the buttocks. An impact hammer (PCB Piezotronics, Inc., 086C03) was employed to generate movement artifact on ECG signal associate with mechanical vibration. Ten successive impacts were struck manually on a certain point of the cushion at intervals of 2 seconds. Voltage from the impact hammer that is proportional to force of the hammer was also recorded simultaneously with ECG signal.

After the each measurement for two types of electrode unit, ten peak-to-peak amplitudes of movement artifact were collected. Ten peak amplitudes of force of impact hammer corresponding to the artifact were also collected. Finally, the averaged value of movement artifact amplitude per unit force

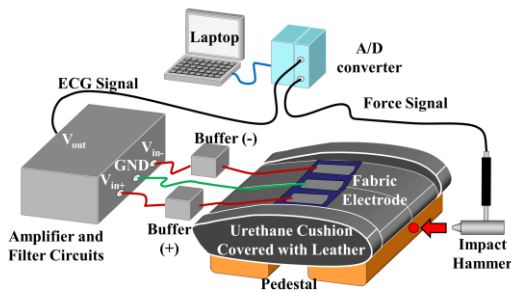
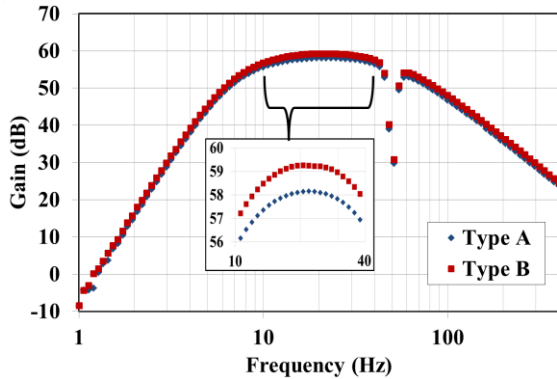

Figure 4. Experimental setup for measuring ECG and movement artifact.



(in order to reduce the variation in the force of the impact hammer), standard deviation and test of significance were calculated from the collected data.

III. RESULTS AND DISCUSSIONS

A. Frequency-Gain Characteristics

As shown in Fig. 5, gains of type B from 10 to 40 Hz have increased by about 1 dB compared to type A. Since the driven shield technique was introduced not only to fabric electrode of type B but also to connecting cables between the buffer circuits and the electrode, the increase of the gain is thought to be by virtue of reduction of stray capacitance in the cable and also of increase of input impedance in the buffer circuit. In the subsequent analysis, the gain was set to 60dB to ignore the error.

B. Recordings of ECG and the SNR using ECG Generator

As can be seen in Fig. 6, ECG amplitude of QRS complex was clearly obtained by each fabric electrode. Fig. 7 shows a more detailed analysis of averaged SNR (SNR_{AVE}). By using each electrode, ECG was detected in the high quality over 35 dB. However, SNR_{AVE} measured by fabric electrode of type B was 3.8 dB significantly smaller than by type A.

C. Recordings of Movement Artifact on ECG of Participants

Comparison of movement artifact amplitude among two configurations demonstrated that type B have a potential to reduce the artifact amplitude, as can be seen in Figs. 8, 9 and 10.

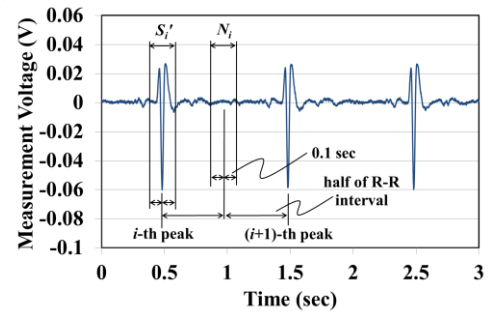

(a) Type A

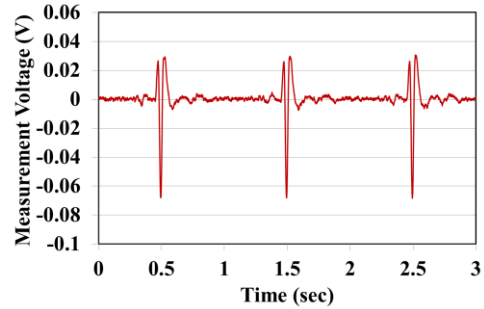

(b) Type B

Figure 6. Recorded signal of simulated ECG.

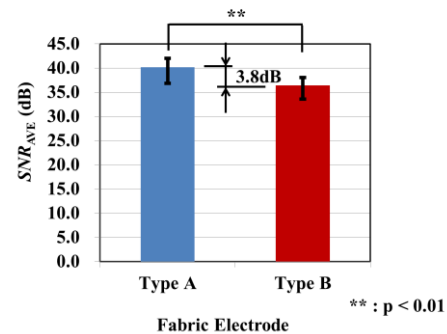

Figure 7. SNR_{AVE} of ECG for each electrode unit.

Fig. 8 shows typical recordings of movement artifact on ECG induced by impact force. These recordings were obtained from measuring participant P4. From the point of view of equivalent force (about 90 N) of impact hammer, the waveform of each fabric electrode was selected.

Fig. 9 shows typical relationship between amplitude of movement artifact and force of impact hammer on measuring them about participant P4. As can be seen in the figure, there was variability of force of impact hammer and movement artifact amplitude per unit force shown in Fig. 10 was calculated in order to reduce the variation.

According to Fig. 10, movement artifact amplitude per unit force of type B was significantly smaller than type A. And therefore fabric electrode unit of type B having multi-layer structure was better performance in terms of movement artifact reduction from interference of triboelectricity. To

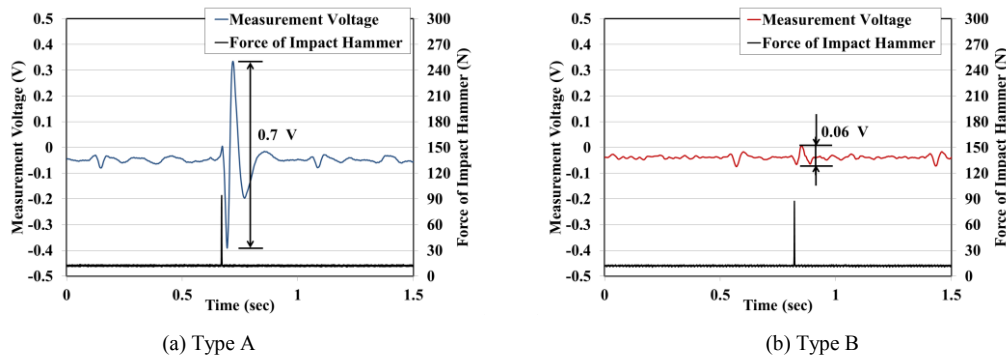

Figure 8. Typical recordings of movement artifact on ECG induced by impact hammer (participant P4).

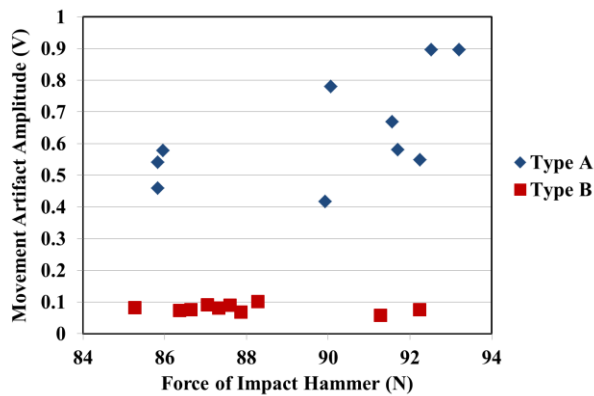

Figure 9. Typical relationship between movement artifact amplitude and force of impact hammer (participant P4).

reveal difference of artifact amplitudes of each participant, it will be necessary to experiments based on the participant's weight, posture and so on.

The multi-layered fabric electrode unit such as type B have a movement artifact reduction function for triboelectricity of the outside of the sensing electrode but don't have it for the inside. For the higher artifact reduction performance, it is necessary to develop novel functions onto the inside of the electrodes and signal processing using a high-precision reference signal.

IV. CONCLUSION

An electrode configuration composed of multi-layered fabric electrodes were examined and compared with that composed of non-layered fabric electrodes in terms of movement artifact reduction when using the electrodes in capacitive electrocardiogram measurement from human buttocks in a vibrating environment. The multi-layered configuration reduced amplitude of movement artifact significantly than the non-layered configuration.

REFERENCES

[1] A. Ueno, Y. Akabane, T. Kato, H. Hoshino, S. Kataoka, and Y. Ishiyama, "Capacitive sensing of electrocardiographic potential through cloth from the dorsal surface of the body in a supine position: A

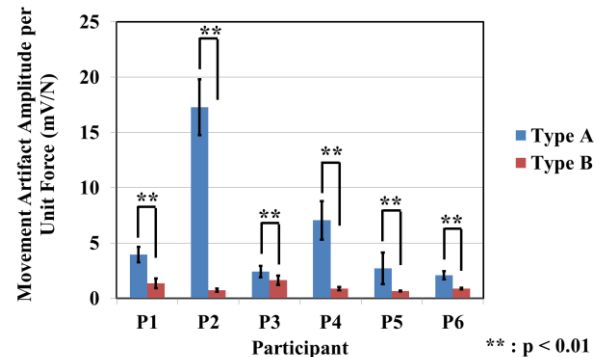

Figure 10. Amplitude of movement artifact per unit force.

preliminary study," *IEEE Trans. Biomed. Eng.*, vol. 54, no. 4, pp. 759-766, Apr. 2007.

[2] H. J. Baek, G. S. Chung, K. K. Kim, K. S. Park, "A smart health monitoring chair for noninvasive measurement of biological signals," *IEEE Trans. Inf. Technol. Biomed.*, vol. 16, no. 1, pp. 150-158, Jan. 2012.

[3] T. Imai and A. Ueno, "ECG monitoring of the driver and the passenger with capacitive seat sensors," *Trans. Jpn Soc. Med. & Biol. Eng.*, vol.47, suppl.1, Kobe, 2008, pp.898-899. (in Japanese)

[4] T. Matsuda, M. Makikawa, "ECG monitoring of a car driver using capacitively-coupled electrodes," in *Proc. 30th Annu. Int. Conf. IEEE EMBS*, Vancouver, 2008, pp.1315-1318.

[5] A. Ueno, Y. Furusawa, H. Hoshino and Y. Ishiyama, "Detection of electrocardiogram by electrodes with fabrics using capacitive coupling," *IEEJ Trans. Electronics, Information and Systems*, vol.124, no.9, pp.1664-1671, Sep. 2004. (in Japanese)

[6] B. Eilebrecht, T. Wartzek, J. Lem, R. Vogt, S. Steffen, "Capacitive electrocardiogram measurement system in the driver seat," *ATZ worldwide eMagazines*, vol. 113, pp. 50-55, 2011.

[7] S. Heuer, B. Chamadiya, A. Gharbi, C. Kunze, and M. Wagner, "Unobtrusive in-vehicle biosignal instrumentation for advanced driver assistance and active safety," in *2010 IEEE EMBS Conf. on Biomedical Engineering & Sciences (IECBES 2010)*, Kuala Lumpur, Malaysia, 2010, pp. 252-256.

[8] Y. Kondo, K. Sasaki, Y. Nakano, S. Sano, and H. Tomimori, "Reduction of baseline fluctuation in Electrocardiogram measurement for a car driver," in *TENCON 2010 - 2010 IEEE Region 10 Conference*, 2010, pp. 1738-1741.

[9] T. Wartzek, B. Eilebrecht, J. Lem, H-J. Lindner, S. Leonhardt, M. Walter, "ECG on the road: robust and unobtrusive estimation of heart rate," *IEEE Trans. Biomed. Eng.*, vol. 58, iss. 11, pp. 3112-3120, Nov. 2011.