

A Capacitive Sensor System for Measuring Laplacian Electromyogram through Cloth: A Pilot Study

Akinori Ueno*, *Member, IEEE*, Yoshinori Uchikawa, *Member, IEEE* and Makoto Noshiro, *Member, IEEE*

Abstract—A possibility for capacitive sensor system for measuring the surface Laplacian electromyogram (Laplacian EMG) was studied under conditions whereby a thin cloth was inserted between the electrodes and the skin of the subject. The system was designed based on a tri-polar concentric electrode unit and on a principle of the capacitive electrode involving the conductive electrodes, the cloth, and the skin. A pilot sensor and detecting circuit using this design were assembled and evaluated to explore the feasibility of this approach. The experimental results showed that the Laplacian EMG obtained in this way was comparable and synchronized with the surface EMG obtained using traditional bipolar electrodes, although its S/N was reduced. Though there are still a lot of challenges to be addressed to achieve practical performances, it seems promising for use in human-machine interfaces because the proposed approach eliminates discomfort due to conventional electrode-to-skin coupling.

I. INTRODUCTION

SINCE the late 1970s myoelectric potential (or Electromyogram: EMG) has been studied and used for biosignal-based mechatronics interfaces such as artificial limb prostheses [1]–[4], robot hands [5], and manipulators [6]. Recently, the EMG has opened up new possibilities for other human-computer interfaces in the fields of augmentative and alternative communication [7]–[10] and environmental control [11]. The EMG contains information on muscle recruitment, timing pattern, and force. Moreover, as users become proficient in the operation of these interfaces, the EMG used for them adapts its waveform to the degree of proficiency. Therefore, the EMG is useful as an input signal for Human Adaptive Mechatronics [12].

In conventional surface EMG (sEMG) measurements, an electrolytic paste or a conductive adhesive is almost always required for maintaining reliable ohmic contact with the skin. Therefore, long-term sEMG measurement using conventional methods causes irritation and discomfort, and is a potential cause of skin allergy and inflammation. These are considerably disadvantageous for the use of sEMG in interfaces, because practical interfaces must be as noninvasive and nonintrusive as possible to gain broad

*A. Ueno is with the Department of Electrical and Electronic Engineering, Tokyo Denki University, 2-2 Nishiki-cho, Kanda, Chiyoda-ku, Tokyo 101-8457, Japan (phone: +81-5280-3301; e-mail: ueno@eee.dendai.ac.jp).

Y. Uchikawa is with the Department of Electronic and Computer Engineering, Tokyo Denki University, Saitama 350-0394, Japan

M. Noshiro is with the Department of Clinical Engineering, School of Allied Health Sciences, Kitasato University, Kanagawa 228-8555, Japan

acceptance from ordinary users.

To overcome these disadvantages, we have focused on the principle of capacitive sensing, which allows detection of alternating electrical potential through an inserted thin insulator, and have applied it to the measurement of Laplacian EMG through commonly available cloth. In order to explore the feasibility and applicability of this concept, we have assembled and evaluated a pilot system based on this approach.

II. CAPACITIVE SENSING

Capacitive sensing is based on the principle of the capacitive (or insulated) electrode, which is an electrode requiring no electrolytic paste or conductive adhesive. A conductive electrode is capacitively coupled with the skin through an insulator, as shown in figure 1. The electrode can carry an alternating bioelectrical current equivalently through the capacitance of the coupling. In previous studies, various insulators, such as anodized aluminum [13], [14], silicon dioxide [15], [16], pyre varnish [17], anodic insulated tantalum oxide [18], and barium titanate [19] have been tested, because these materials exhibit high permittivity. In the present study, commonly available cloth, such as woven cotton, was substituted for these rigid insulators to relieve the irritation, allergy and discomfort experienced with conventional skin-to-electrode coupling. Also a sheet of conductive fabric was substituted for the conventional metal electrode so that it could deform and allow closer adhesion to the contour of the coupled region. In addition, capacitive sensing is facilitated by an impedance transforming circuit to match the high impedance of the coupling to the low impedance required by the subsequent circuitry. A FET source follower has been used as an impedance transforming

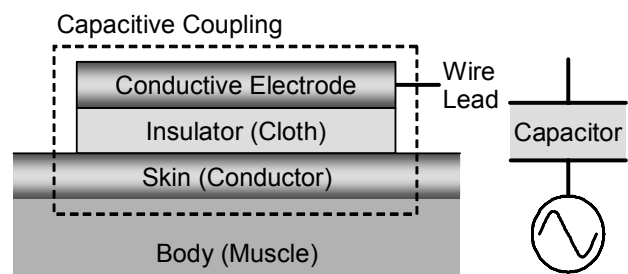

Fig. 1. A schematic model of the capacitive electrode coupled to the skin with the inserted cloth and its equivalent circuit.

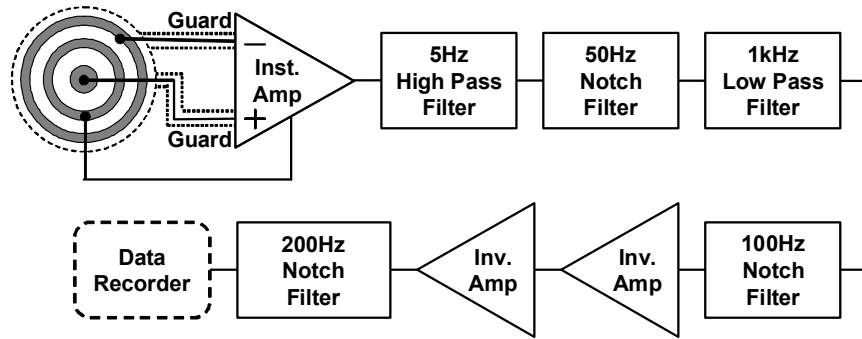

Fig. 2. Configuration of the concentric ring electrode for Laplacian derivation and block diagram of the detecting circuit.

circuit and mounted actively in an electrode housing [16], [17] for reducing common mode interference caused by power lines. In the present study, an instrumentation amplifier having high input impedance ($1000T\Omega$ according to the specification sheet) was employed to match the greater impedance of the coupling due to the smaller dielectric constant of the inserted cloth in comparison with the conventional insulators. The impedance transforming circuit was not mounted in the electrode housing so that hard contact with the skin was avoided.

III. THEORETICAL BASIS OF BODY SURFACE LAPLACIAN

Considering a local orthogonal coordinate system (x, y, z) with origin at a point on the body surface where the z axis is orthogonal to the body surface, the Laplacian EMG, L_S , is defined by applying a Laplacian operator to the body surface potential ϕ as follows:

$$L_S = -\nabla_{xy}^2 \phi \equiv -\left(\frac{\partial^2 \phi}{\partial x^2} + \frac{\partial^2 \phi}{\partial y^2}\right) = -\left(\frac{1}{\sigma}\right) \frac{\partial J_z}{\partial z}. \quad (1)$$

Thus the Laplacian EMG signal is negatively proportional to the normal derivative of the normal component of the current density at the body surface. Therefore, Laplacian EMG is supposed to be sensitive to the firing of the muscle right under the site at the measurement. Accordingly, the signal is potentially useful as an input for human interfaces, because it is less susceptible to the interferences caused by the activity of approximal muscles than the EMG signal conventionally obtained with single differential electrode configuration.

IV. MATERIALS AND METHODS

A. Tri-polar Concentric Ring Electrode

The surface Laplacian EMG signal was picked up using tri-polar concentric ring electrode made of conductive fabric with conductive acrylic adhesive (3M, 2191FR), as shown in Fig.2. The area of two rings and the center disk was set to 10cm^2 , respectively. The electrode was stuck to an insulating support made of flexible chloroethylene, and a convex

connector (5ϕ) was inserted between the support and each ring or the center disk. The skin-cloth-electrode coupling was held by a stretch rubber band. The two lead electrodes were connected to a measuring device, to be described in the next section, by shielded wires.

B. Signal Detection

The detecting circuit with filters and amplifiers was assembled using off-the-shelf components. The circuit consists of an instrumentation amplifier, a Butterworth high-pass filter, three notch filters, a Butterworth low-pass filter and two inverting amplifiers. Fig. 2 shows a block diagram of the circuit. The instrumentation amplifier was employed not only as a differential amplifier but also as the impedance transforming circuit. The circuit constants in the high-pass filter and the low-pass filter were set to obtain a cutoff frequency of 5 and 1000 Hz, respectively. Three notch filters were used to reduce 50, 100, and 200 Hz interference. The guard ring technique was employed in the lead wires between the instrumentation amplifier and the electrodes so as to reduce the interference.

C. Measurement of Frequency Response of the Sensor

A dedicated experimental setup was used to measure the frequency responses of the developed sensing system. Three measuring electrodes having an identical rectangle figure and an area of 10cm^2 were placed on an insulating support and covered with a cotton sheet $350\mu\text{m}$ thick. Then, three synthetic skins made of a rectangle piece of the conductive fabric having the same figure and area as the measuring electrode were attached to the cloth at locations just above each of the measuring electrodes, so that the whole area of each measuring electrode was involved in the capacitive coupling with each synthetic skin. Using a weight, the electrodes, the cloth and the synthetic skins were subjected to a pressure of 424 Pa, mimicking a pressure less than the mean pressure which was exerted by the rubber band for electrode fixation. Sinusoidal waves from 0.5 to 5000 Hz were input

from an oscillator to the synthetic skins, and then the outputs from the system were measured. A frequency response without any cloth inserted was also measured from 0.5 to 5000 Hz. The data were digitized at 10 kHz sampling rate by a 16-bit A/D converter and stored in a personal computer using a data acquisition system (Biopac Systems, MP-150 system).

D. Simultaneous Measurement with a Commercially Produced Electromyograph

One male volunteer aged 21 was instructed to sit down on a chair. The surface of the left thigh of the subject was covered with a cotton cloth 350 μm thick without any preparation. The tri-polar concentric ring electrode was held on the left rectus femoris muscle over the cloth using the rubber band. A Laplacian EMG signal was recorded using the developed system from the site, while the subject repeated isometric contraction and relaxation of the muscles. As a reference signal, a directly measured surface EMG (sEMG) signal was wirelessly recorded using a commercially produced bioamplifier (Teac Instruments, BA1104M) and a telemeter unit (Teac Instruments, TU-4). Two disposable electrodes (Nihon Kohden, Vitrode F-150M) were attached directly to the skin at both sides of the electrode along with the muscle fibers. A body earth electrode for the conventional measurement was placed the left knee. The output signal from the developed system and the reference signal were simultaneously digitized at 10 kHz sampling rate by the 16-bit A/D converter and stored in the personal computer.

V. RESULTS AND DISCUSSION

A. Frequency Response of the Device

The frequency-gain response without any inserted cloth (labeled “Direct”) showed flat gains of about 66 dB within the frequency range 5 to 1000 Hz with exceptions at 50, 100, and 200 Hz, as designed (Fig.3). Because these characteristics are comparable with those required for the conventional electromyograph in the specific standard, the developed device can be utilized to measure the ordinary electromyogram, when the electrode unit is attached directly to the skin. Furthermore, the frequency-gain response with the 350- μm cloth inserted (labeled “With cloth”) had almost flat gains around 64 dB within the frequency range 0.4 to 1200 Hz. Therefore, the developed device can detect EMG, even when the cloth is inserted between the electrode unit and the skin.

B. Simultaneous Measurement with a Conventional Device

Fig.4 shows typical recordings obtained from the rectus femoris muscle. The output signal of the developed system showed firings synchronized with the reference sEMG. Although the waveforms were not completely identical

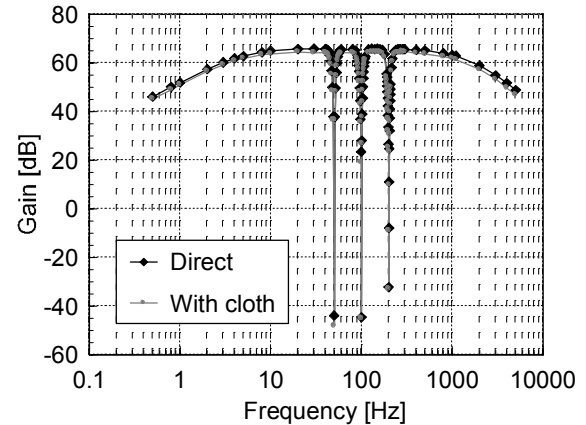

Fig. 3. Frequency responses of the gain measured directly from the measuring electrode (labeled “direct”), and with the 350- μm cloth inserted (labeled “with cloth”). The black and grey dotted lines indicate -3 dB from the maximum gain in each condition. The gains at 50, 100, and 150 Hz were sharply attenuated because notch filters were used in the device. The room temperature was 22 $^{\circ}\text{C}$ and the relative humidity was 38% during the measurement.

because the configurations of the electrode and detection sites were different, Laplacian EMG was successfully detected from the site even with the cloth inserted. Greater noise was probably due to the higher input impedance of the developed system. Therefore, improvement of S/N remains to be investigated in a further study.

VI. CONCLUSION

We have studied a possibility of capacitive sensor system for obtaining the surface Laplacian EMG under conditions whereby a thin cloth is inserted between the electrodes and the skin. We fabricated a pilot sensor and detecting circuit, and validated the system. Examination of the system yielded the following results.

- 1) Frequency-gain responses indicated that the system was sufficiently capable of detecting Laplacian EMG not only when the electrode unit was attached directly to the skin, but also when a 350- μm cotton cloth was inserted between the electrode and the skin.
- 2) Despite the fact that when the cloth was inserted the S/N of the detected signal worse than that of conventional devices, this method was able to yield a clearly visible Laplacian EMG from the rectus femoris muscle even with the cloth inserted.

Since the proposed method eliminates discomfort due to conventional skin-to-electrode coupling, the proposed method appears worth addressing towards practical application.

VII. CHALLENGES FOR THE FUTURE

At this time, the following challenges remain to be addressed for the future.

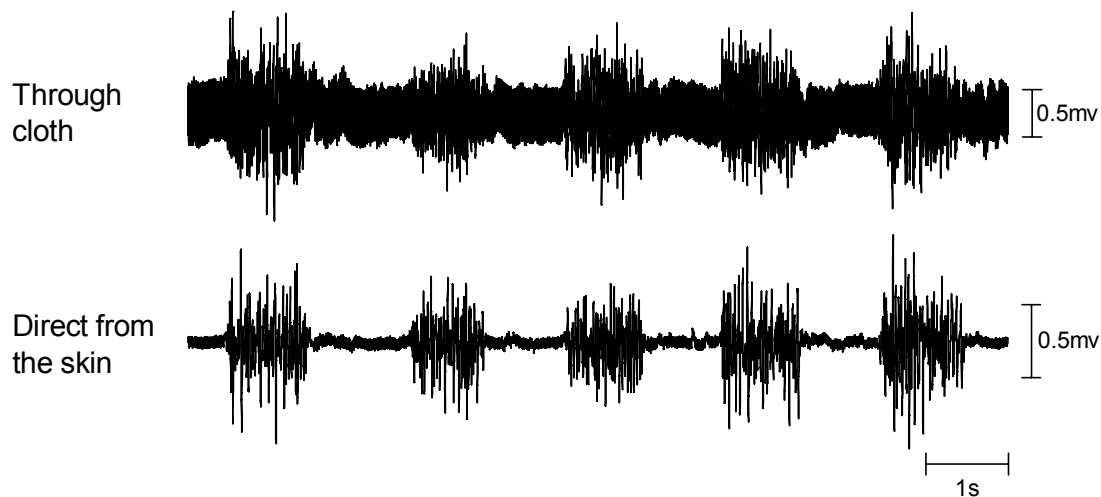

Fig. 4. Simultaneous recordings from rectus femoris muscle using the developed device with a cotton sheet 350 μm thick (top) and using a conventional electromyograph without any cloth (bottom).

- 1) Downsizing of the electrode unit
- 2) Improvement of S/N without any notch filters
- 3) Enhancement of motion artifact robustness
- 4) Combination with wireless module
- 5) Refinement of fixation manner

REFERENCES

- [1] D. Graupe, J. Magnussen, and A. A. Beex, "A microprocessor system for multifunctional control of upper-limb prostheses via myoelectric signal identification," *IEEE Trans. Automat. Contr.*, vol.AC-23, pp.538-544, 1978.
- [2] S. C. Jacobson, D. F. Knutti, R. T. Johnson, and H. H. Sears, "Development of the Utah artificial arm," *IEEE Trans. Biomed. Eng.*, vol.BME-29, pp.249-269, 1982.
- [3] E. Park and S. G. Meek, "Adaptive filtering of the electromyographic signal for prosthetic control and force estimation," *IEEE Trans. Biomed. Eng.* vol.42, pp.1048-1052, 1995.
- [4] D. Peleg, E. Braiman, E. Yom-Tov, and G. F. Inbar, "Classification of finger activation for use in a robotic prosthesis arm," *IEEE Trans. Neural Syst. Rehab. Eng.* vol.10, pp.290-293, 2002.
- [5] K. A. Farry, I. D. Walker, R. G. Baraniuk, "Myoelectric teleoperation of a complex robotic hand," *IEEE Trans. Robot. Automat.*, vol.12, pp.775-788, 1996.
- [6] O. Fukuda, T. Tsuji, M. Kaneko, and A. Otsuka, "A human-assisting manipulator teleoperated by EMG signals and arm motions," *IEEE Trans. Robot. Automat.*, vol.19, pp.210-222, 2003.
- [7] A. B. Barreto, S. D. Scargle and M. Adjouadi, "A practical EMG-based human-computer interface for users with motor disabilities," *J. Rehab. Res. Develop.*, vol.37, pp.53-64, 2000.
- [8] V. Stanford, "Biosignals offer potential for direct interfaces and health monitoring," *IEEE Pervasive Comput. Mag.*, vol.3, pp.99-103, 2004.
- [9] E. A. Goldstein, J. T. Heaton, J. B. Kobler, G. B. Stanley, and R. E. Hillman, "Design and implementation of a hands-free electrolarynx device controlled by neck strap muscle electromyographic activity," *IEEE Trans. Biomed. Eng.*, vol.51, pp.325-32, 2004.
- [10] K. Miyazawa, A. Ueno, H. Mori, H. Hoshino, and M. Noshiro, "Development and evaluation of a wireless interface for inputting characters using Laplacian EMG," in *Proc. 28th Ann. Int. Conf. IEEE EMBS (New York)*, pp.2518-2521, 2006.
- [11] H. Ogino, J. Arita, and T. Tsuji, "Wearable pointing device using EMG signals," *J. Robot. Mechatron.* vol.17, pp.173-180, 2005.
- [12] K. J. Åström, M. Iwase, K. Furuta and J. Åkesson, "Safe manual control of pendulums—A Human Adaptive Mechatronics perspective-," *Int. J. Assist. Robot. Mechatron.*, vol.7, pp.3-11, 2006.
- [13] P. C. Richardson, F. K. Coombs, and R. M. Adams, "Some new electrode techniques for long term physiologic monitoring," *Aerosp. Med.*, vol.39, pp.745-750, 1968.
- [14] J. A. Lopez, and P. C. Richardson, "Capacitive electrocardiographic and bioelectric electrodes," *IEEE Trans. Biomed. Eng.*, vol.BME-16, p.99, 1969.
- [15] R. N. Wolfson and M. R. Neuman, "Miniature Si-SiO₂ insulated electrodes based on semiconductor technology," in *Proc. 22nd ACEMB (Chicago)*, 1969.
- [16] W. H. Ko, M. R. Neuman, R. F. Wolfson, and E. T. Yon, "Insulated active electrode," in *Proc. Int. Conf. IEEE Solid-State Circuits*, pp.195-198, 1971.
- [17] A. Potter and L. Menke, "Capacitive type of biomedical electrodes," *IEEE Trans. Biomed. Eng.*, vol.BME-17, pp.350-351, 1970.
- [18] C. H. Lagow, K. J. Sladek, and P. C. Richardson, "Anodic insulated Tantalum Oxide electrocardiograph electrodes," *IEEE Trans. Biomed. Eng.*, vol.BME-18, pp.162-164, 1971.
- [19] T. Matsuo, M. Esashi, and K. Iinuma, "Capacitive electrode for biomedical use -The use of Barium-titanate ceramics for biomedical sensing electrode-," *Japan. J. Med. Electron. Biol. Eng.* vol.11 pp.10-16, 1973. (in Japanese)
- [20] H. Sato, "Some factors effecting the power spectra of surface electromyograms in isometric contractions," *J. Anthropol. Soc. Nippon*, vol.84, pp.137-45, 1976.
- [21] L. A. Geddes and M. E. Valentinuzzi, "Temporal changes in electrode impedance while recording the electrocardiogram with dry electrode," *Annals Biomed. Eng.*, vol.1, pp.356-367, 1973.
- [22] A. Ueno, Y. Akabane, T. Kato, H. Hoshino, S. Kataoka, and Y. Ishiyama, "Capacitive sensing of electrocardiographic potential through cloth from the dorsal surface of the body in a supine position—a preliminary study," *IEEE Trans. Biomed. Eng.*, vol.54, no.4, pp.759-766, April 2007